

ITEM NO.	PART NUMBER	DESCRIPTION	QTY.
1	PRO.IMP.BSO-1733	1733 Imperium Outer Base	1
2	PRO.IMP.TCB-1733	1733 Imperium Channel Bearer	2
3	Imperium 1733	Imperium 1733 Inner Tank	1
4	ACC.PI.ST.HSO-1 1-2	Half Socket 1.5"	1
5	PRO.IMP.BVC	Imperium Bund Vent Cover	1
6	ACC.PI.ST.WNI-2	Weld Nipple - 2.0"	1
7	IMP.FPS-GFI	Imperium® Generator Feed Top Fittings Plate (Small) Assembly	1
8	ACC.FPN-2	Aluminium Fill Point Nipple - 2"	1
9	ACC.CAP.CA-2	Cap & Chain Aluminium - 2"	1
10	ACC-PI.DTA.1-1.25	Drop Tube Assembly (Removable) 1" c/w Foot Valve & Strainer - 1.25mt	1
11	PRO.IMP.BOB-O	Imperium Bottom Outlet Blank Plate - Outer	1
12	PRO.IMP.OFS-1733	1733 Imperium Outer Front & Side	1
13	PRO.IMP.OBS-1733	1733 Imperium Outer Back & Side	1
14	PRO.IMP.BLE-S	Imperium Lifting Eye (Standard)	2
15	EXT.IMP.LTB-S	Imperium® Lockable Top Box (small)	1
16	PRO.IMP.AMP	Imperium Alarm Mounting Plate	1

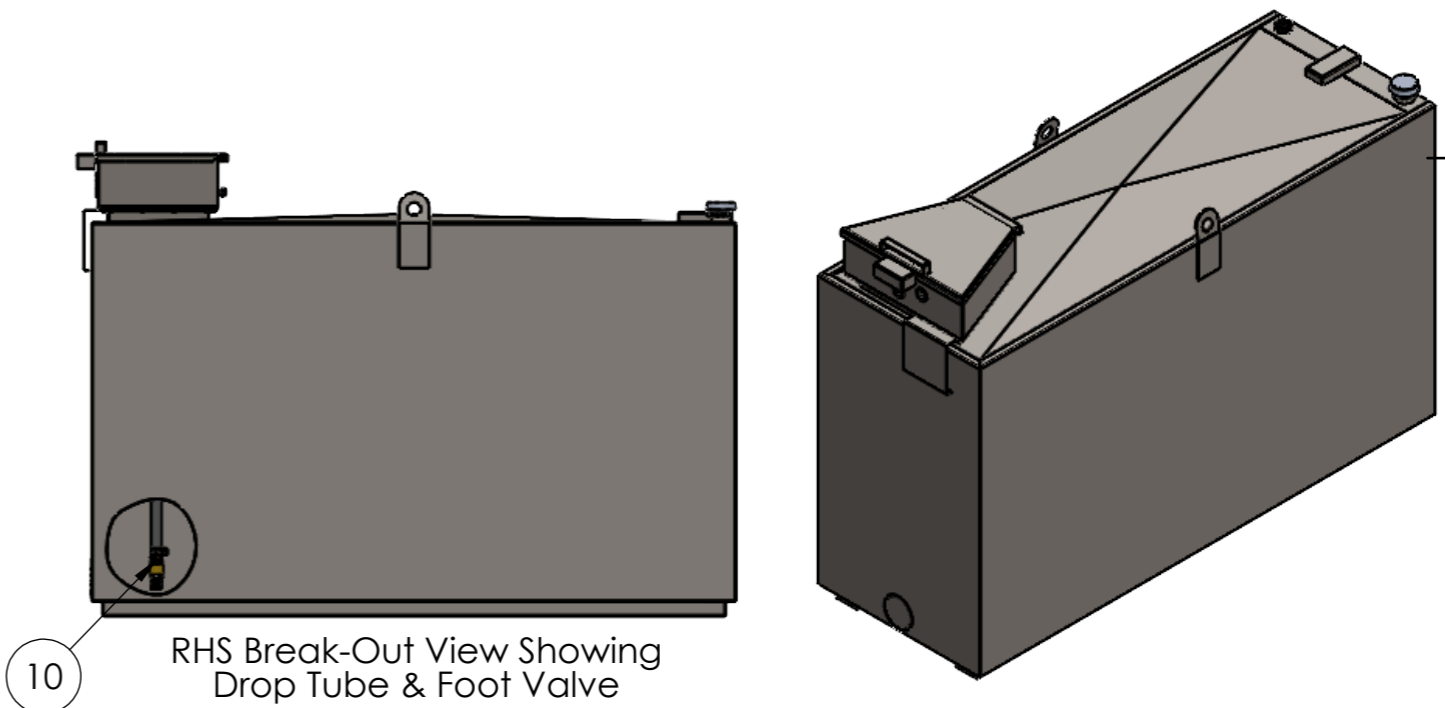

Rev	Mod Date	Mod Description
01	12/02/2026	Initial Drawing

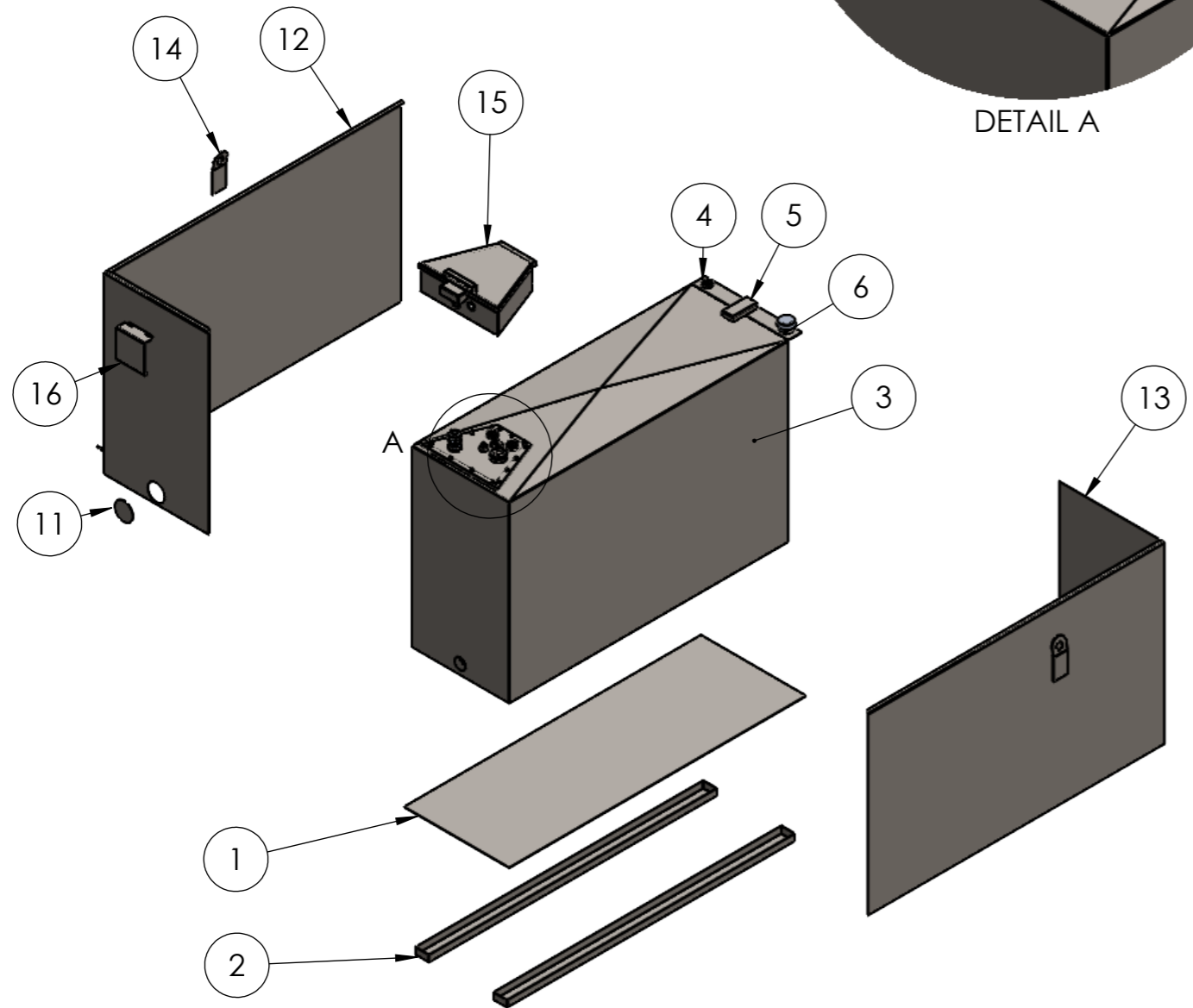
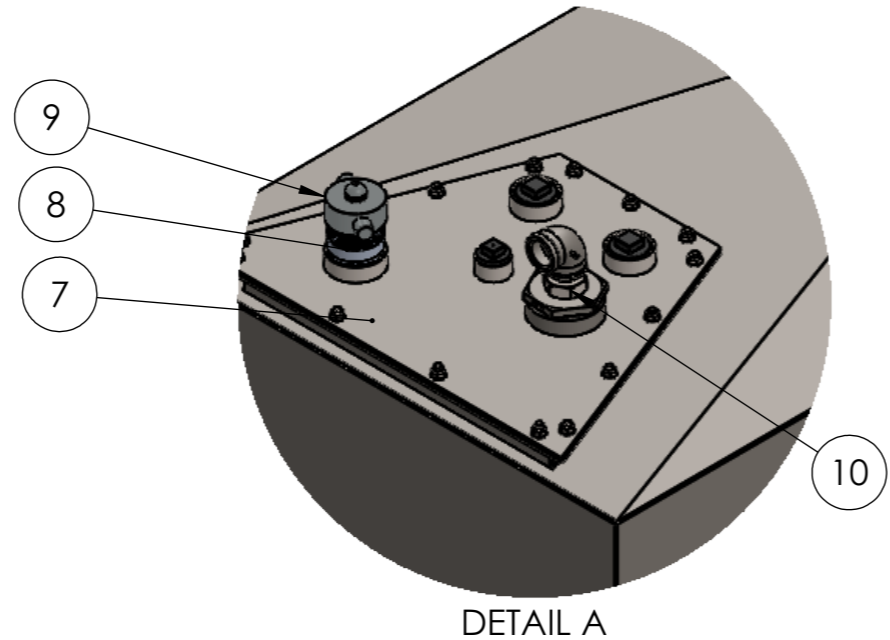

Atlantis Tanks Group Ltd
Tel: +44 (0)330 999 1100
www.atlantistanks.co.uk

THIS DRAWING IS CONFIDENTIAL AND MAY NOT BE USED, COPIED OR DISCLOSED TO ANYONE WITHOUT THE PERMISSION OF ATLANTIS TANKS GROUP LTD 2026

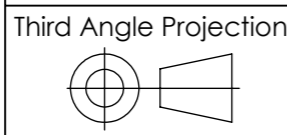

Sheet: 1 OF 2
Tolerances: Upto ±20mm

Product Order Number & Product Code:
TAN.GFI-1733

Dry Weight: 328.36 kg

Title:
1550 Litre Steel Bunded Imperium® Generator Feed Oil Tank (Patent Pending)

Product Range:
Imperium

Scale:	Drawn By	Drawn Date	Checked By	Checked Date	Approved By	Approved Date
DNS	RMS	15/03/2024	KLM	12/02/2026	JRM	12/02/2026

Nozzle Connection	Description	Pipe Size/Socket Size (Inches)
N1	Tank Socket BSPP (F) For Fill Point C/W Drip Cap & Chain	2
N2	Tank Socket BSPP (F) For Generator Return	1
N3	Tank Socket BSPP (F) (2 Posn)	1.5
N4	Tank Socket BSPP (F) For 1" Generator Feed Assembly (C/W Foot Valve & Strainer)	2.5
N5	Tank To Bund Vent	2
N6	Bund Socket BSPP (F)	1.5
N7	Bund Socket BSPP (M) For Bund To Atmosphere Vent	2

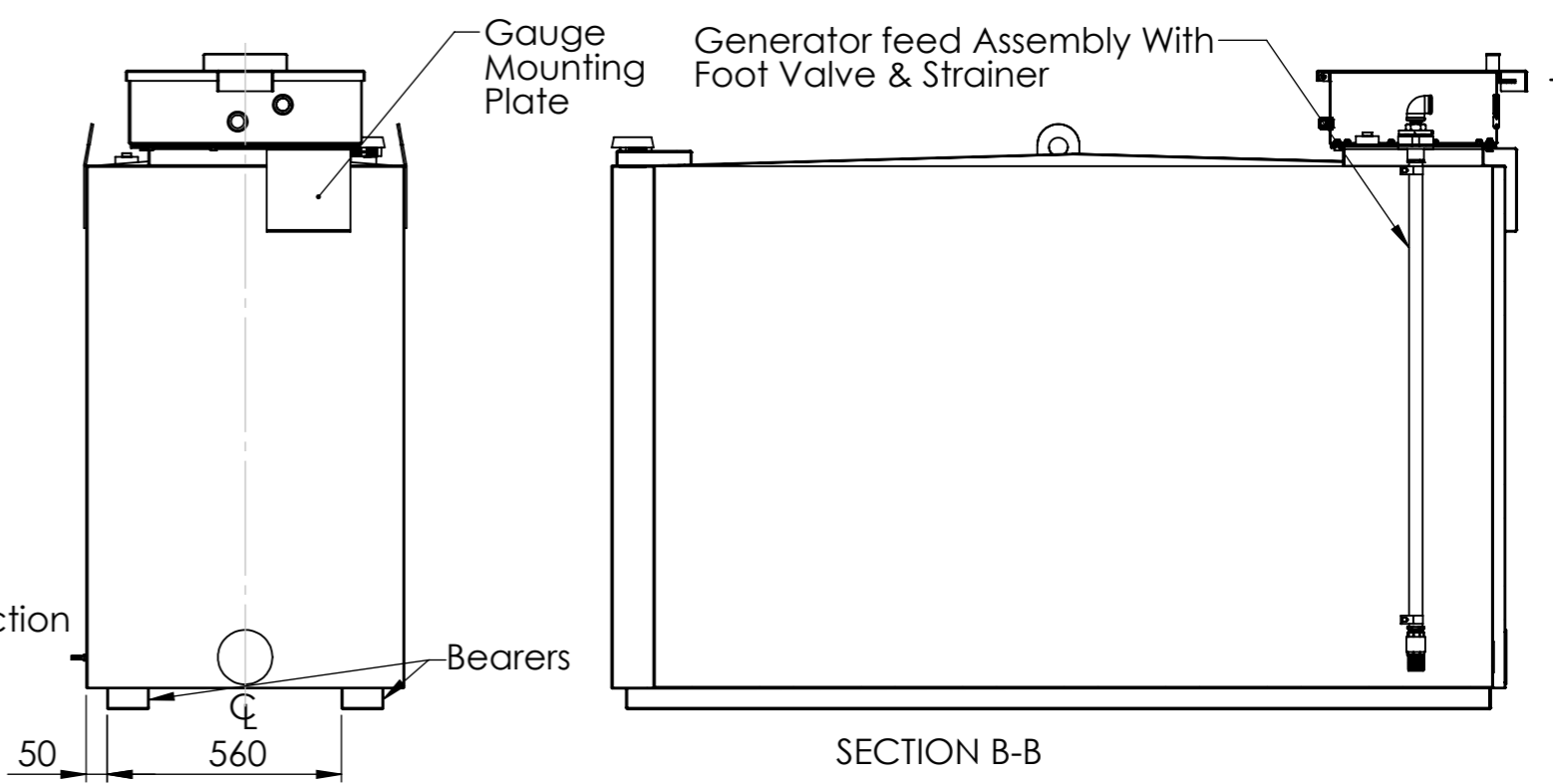
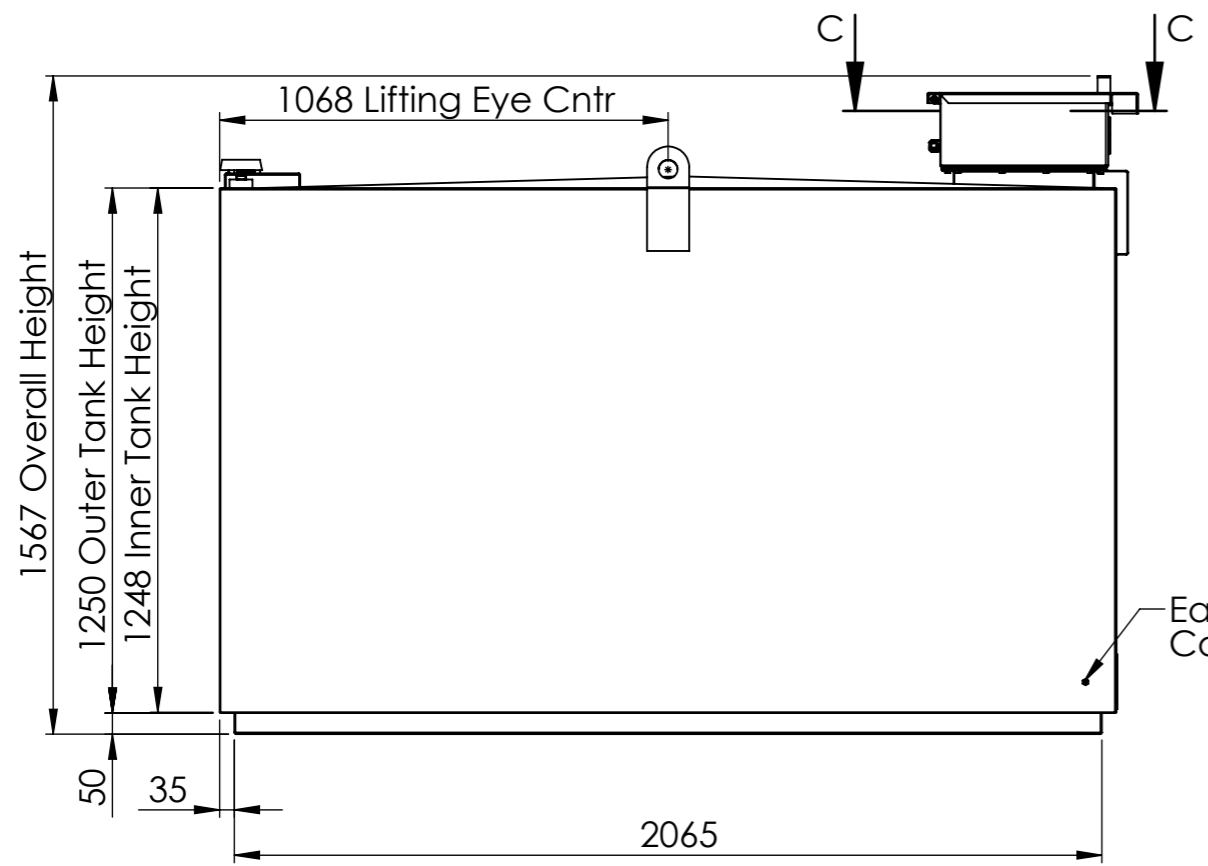
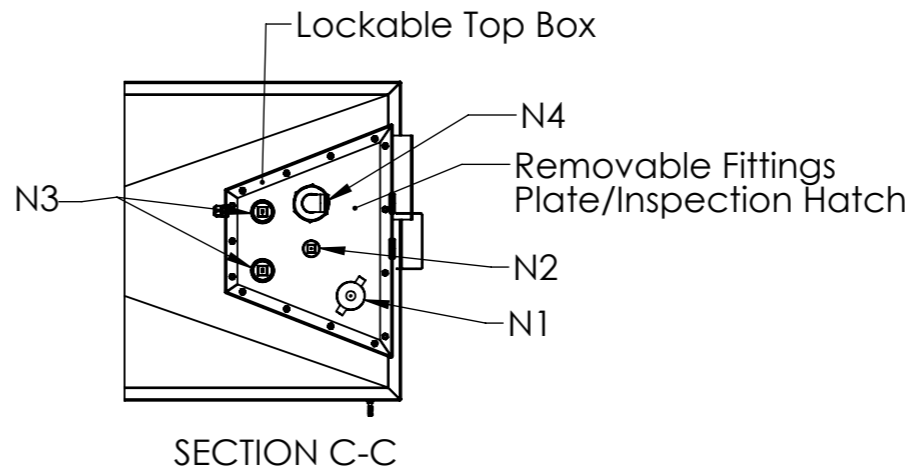
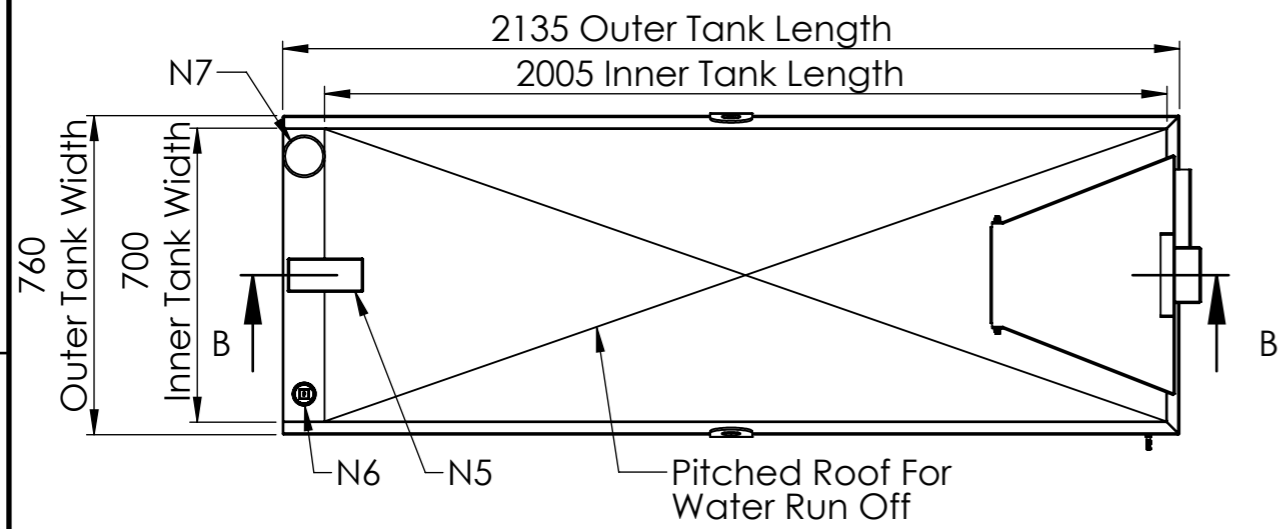

Atlantis Tanks Group Ltd
Tel: +44 (0)330 999 1100
www.atlantistanks.co.uk

THIS DRAWING IS CONFIDENTIAL AND MAY NOT BE USED, COPIED OR DISCLOSED TO ANYONE WITHOUT THE PERMISSION OF ATLANTIS TANKS GROUP LTD 2026

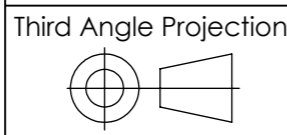

Rev:01

Sheet: 2 OF 2

Product Order Number & Product Code:
TAN.GFI-1733 Customer Drawing

Dry Weight: 328.36 kg

Tolerances: upto ±20mm

Title:
1550 Litre Steel Bunded Imperium® Generator Feed Oil Tank (Patent Pending)

Scale:DNS

Units: mm

Product Range:
Imperium

Drawn By	Drawn Date	Checked By	Checked Date	Approved By	Approved Date
RMS	15/03/2024	KLM	12/02/2026	JRM	12/02/2026