

ITEM NO.	PART NUMBER	DESCRIPTION	QTY.
1	PRO.IMP.BSO-2186	2186 Imperium Outer Base	1
2	PRO.IMP.TCB-2186	2186 Imperium Channel Bearer	3
3	Imperium 2186	Imperium 2186 Inner Tank	1
4	ACC.PI.ST.HSO-1 1-2	Half Socket 1.5"	1
5	PRO.IMP.BVC	Imperium Bund Vent Cover	1
6	ACC.PI.ST.WNI-2	Weld Nipple - 2.0"	1
7	IMP.FPL-GFI	Imperium® Generator Feed Top Fittings Plate (Large) Assembly	1
8	ACC.FPN-2	Aluminium Fill Point Nipple - 2"	1
9	ACC.CAP.CA-2	Cap & Chain Aluminium - 2"	1
10	ACC-PI.DTA.1-1.25	Drop Tube Assembly (Removable) 1" c/w Foot Valve & Strainer - 1.25mt	1
11	PRO.IMP.BOB-O	Imperium Bottom Outlet Blank Plate - Outer	1
12	PRO.IMP.OFS-2186	2186 Imperium Outer Front & Side	1
13	PRO.IMP.OBS-2186	2186 Imperium Outer Back & Side	1
14	PRO.IMP.BLE-S	Imperium Lifting Eye (Standard)	2
15	PRO.IMP.LTB-L	Imperium® Lockable Top Box (large)	1
16	PRO.IMP.AMP	Imperium Alarm Mounting Plate	1

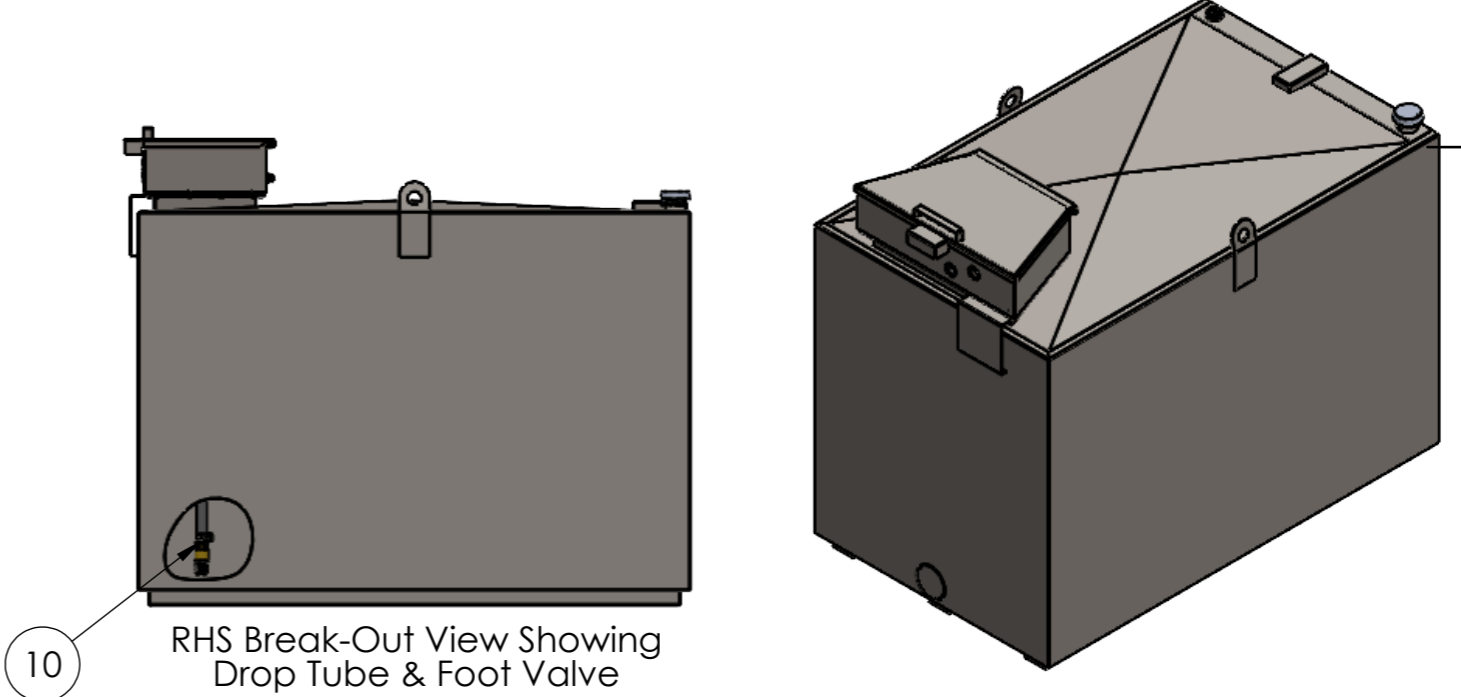

01	13/02/2026	Initial Drawing
Rev	Mod Date	Mod Description
Product Order Number & Product Code: TAN.GFI-2186		Title: 2000 Litre Steel Bunded Imperium® Generator Feed Oil Tank (Patent Pending)
Product Range: Imperium		
Scale:DNS	Drawn By	Drawn Date
Units: mm	Checked By	Checked Date
	Approved By	Approved Date

Atlantis
 Atlantis Tanks Group Ltd
 Tel: +44 (0)330 999 1100
 www.atlantistanks.co.uk

THIS DRAWING IS CONFIDENTIAL AND MAY NOT BE USED,
 COPIED OR DISCLOSED TO ANYONE WITHOUT THE
 PERMISSION OF ATLANTIS TANKS GROUP LTD 2026

Third Angle Projection

Sheet: 1 OF 2
 Tolerances: Upto ±20mm

Product Order Number & Product Code:
TAN.GFI-2186

Dry Weight: 373.79 kg

Scale:DNS	Drawn By	Drawn Date	Checked By	Checked Date	Approved By	Approved Date
Units: mm	RMS	22/03/2024	KLM	13/02/2026	JRM	13/02/2026

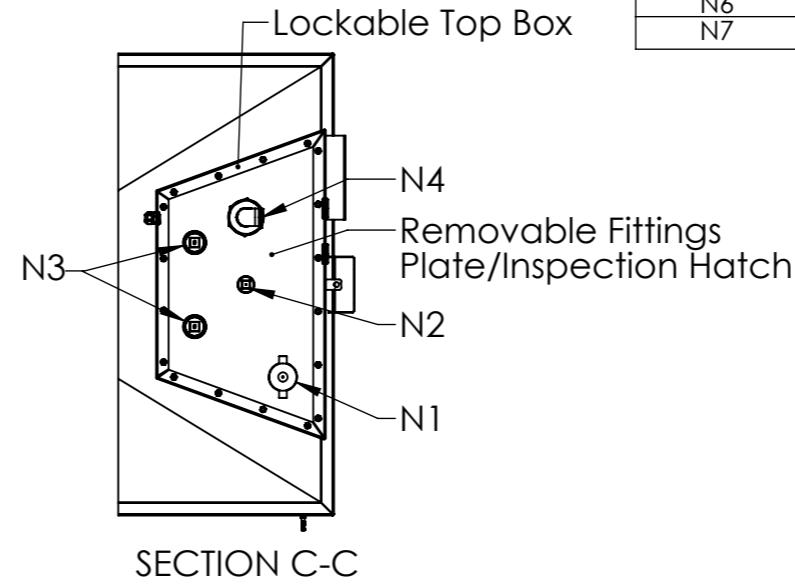
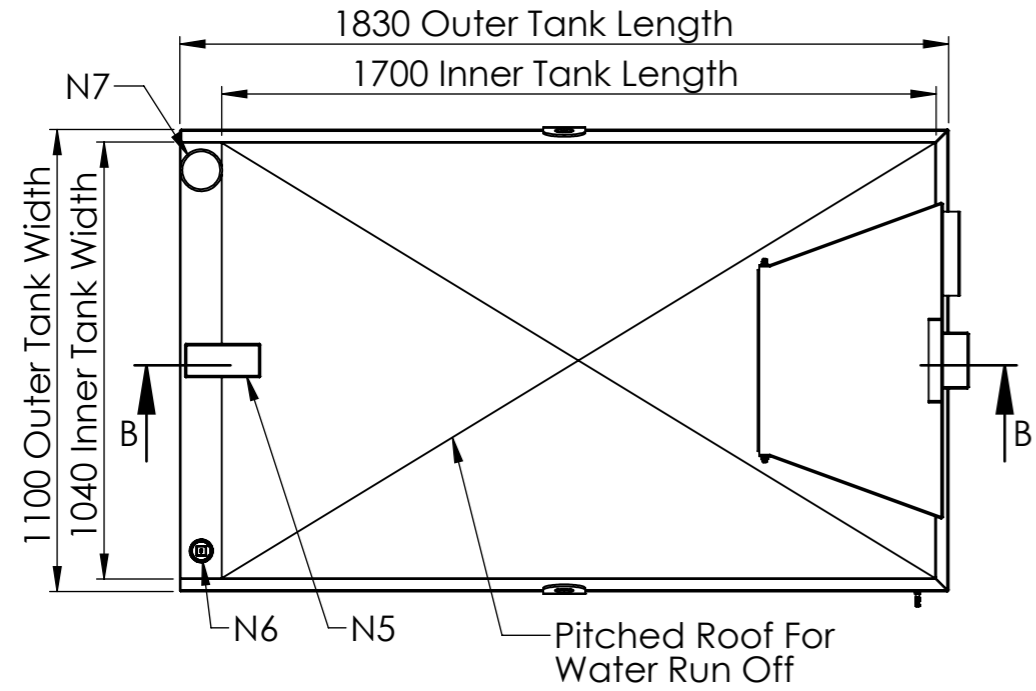

Nozzle Connection	Description	Pipe Size/Socket Size (Inches)
N1	Tank Socket BSPP (F) For Fill Point C/W Drip Cap & Chain	2
N2	Tank Socket BSPP (F) For Generator Return	1
N3	Tank Socket BSPP (F) (2 Posn)	1.5
N4	Tank Socket BSPP (F) For 1" Generator Feed Assembly (C/W Foot Valve & Strainer)	2.5
N5	Tank To Bund Vent	2
N6	Bund Socket BSPP (F)	1.5
N7	Bund Socket BSPP (M) For Bund To Atmosphere Vent	2

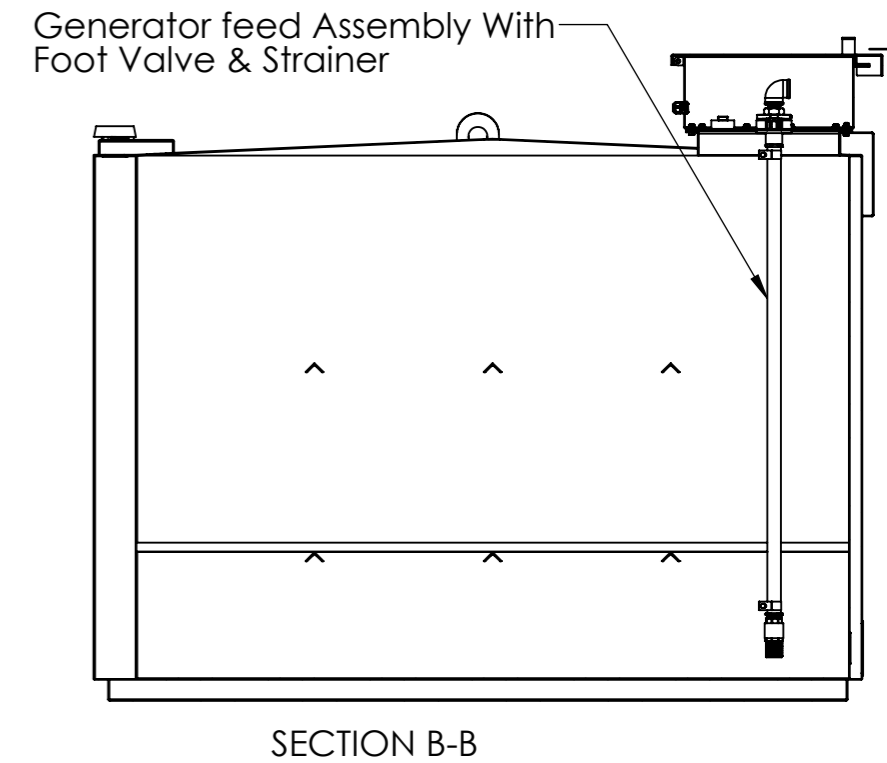
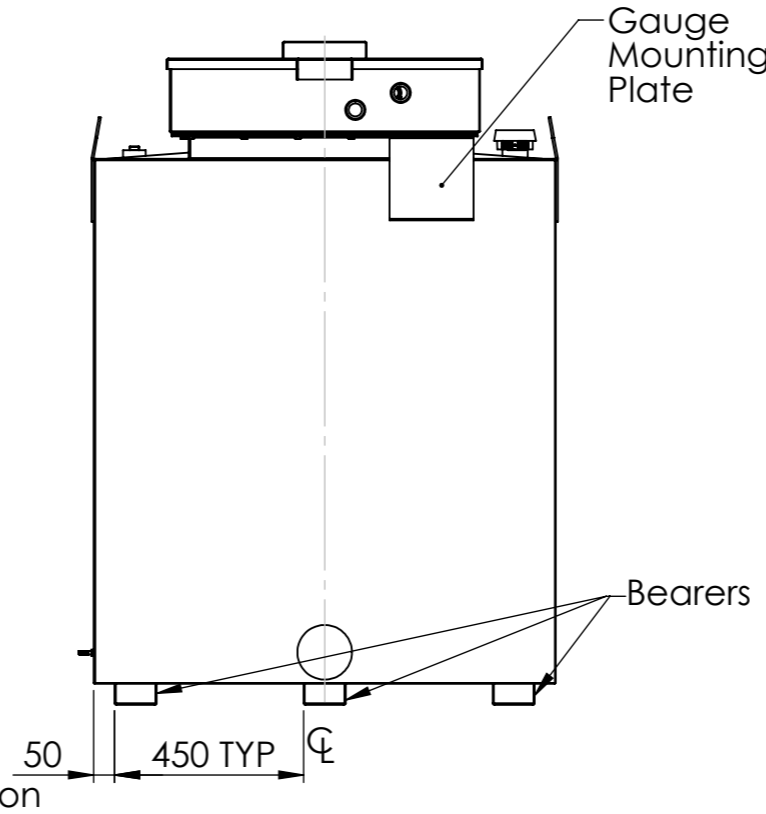
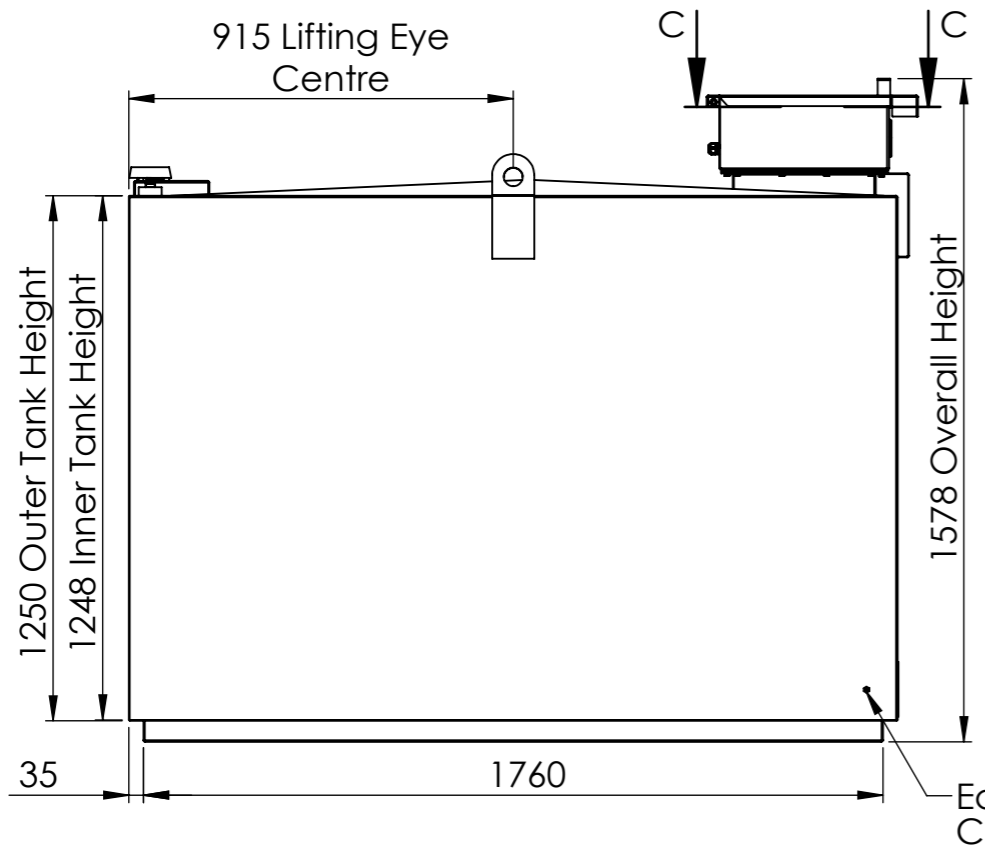

Atlantis Tanks Group Ltd
Tel: +44 (0)330 999 1100
www.atlantistanks.co.uk

THIS DRAWING IS CONFIDENTIAL AND MAY NOT BE USED, COPIED OR DISCLOSED TO ANYONE WITHOUT THE PERMISSION OF ATLANTIS TANKS GROUP LTD 2026

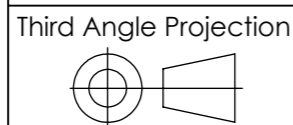

Rev:01

Sheet: 2 OF 2

Product Order Number & Product Code:
TAN.GFI-2186

Dry Weight: 373.79 kg

Tolerances: upto ±20mm

Title:
2000 Litre Steel Bunded Imperium® Generator Feed Oil Tank (Patent Pending)

Scale:DNS

Units: mm

Product Range:
Imperium

Drawn By	Drawn Date	Checked By	Checked Date	Approved By	Approved Date
RMS	22/03/2024	KLM	13/02/2026	JRM	13/02/2026